



**EDUCATIONAL**  
DIRECTIONS

**SWAEC School  
Improvement Partnership  
September 2023**



Download today's presentation and toolkit files on our website at <https://www.eddirections.com/swaec/> or scan the QR code with your phone or device.



## Overview of the Session

- Welcome/Overview
- Section 1 – Application of the LEARNS Act
- Section 2 - Student Learning/Student Performance
- Section 3 - The Rhythm of the Learner Year
- Optional Working Lunch





## Building District/School Capacity

- Philosophy of school improvement
- Data-driven educational decision making
- Meeting students where they are
- Developing school leadership and professional learning communities
- Deescalating intervention model



HOW THE LEARNS ACT HELPS STUDENTS

# The Rhythm of the Learner Year Timeline

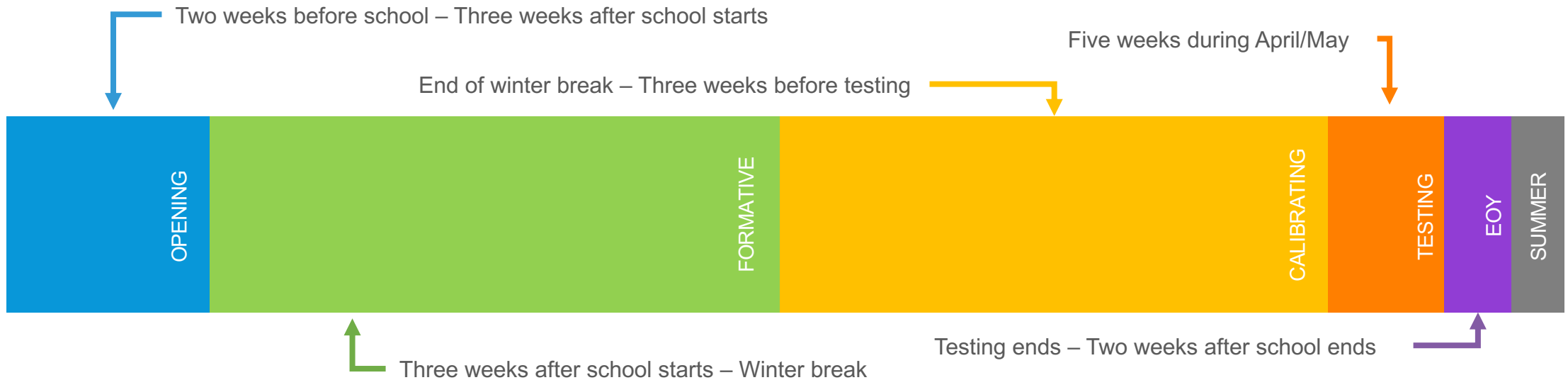





HOW THE LEARNS ACT HELPS STUDENTS

## Arkansas' Education Initiative



**LEARNS**

THE SCHOOL IMPROVEMENT FRAMEWORK

# School Improvement Framework

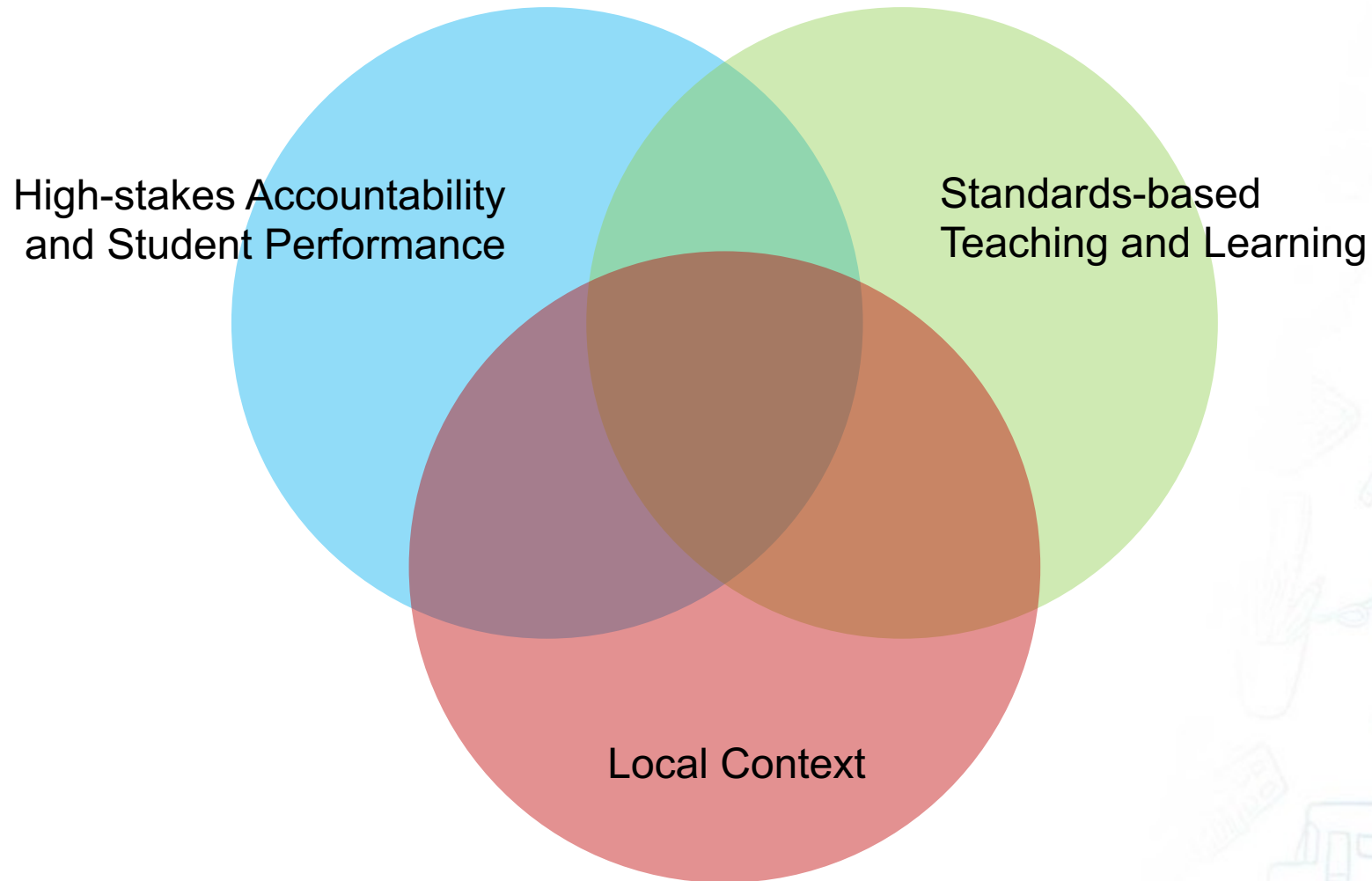

# The State Change Initiative: High-stakes Accountability and Student Performance



High-stakes Accountability  
and Student Performance



## What to Expect from Ed Directions

- Unpack and create meaning for adults and students
- Red Flag Analyses: causal analysis
- Develop a shared vision, goals, and objectives
- Develop data streams that inform decisions
- Ad hoc PLC work and professional development
- End of semester transition report



THE SCHOOL IMPROVEMENT FRAMEWORK

# The State Change Initiative: Standards-based Teaching and Learning

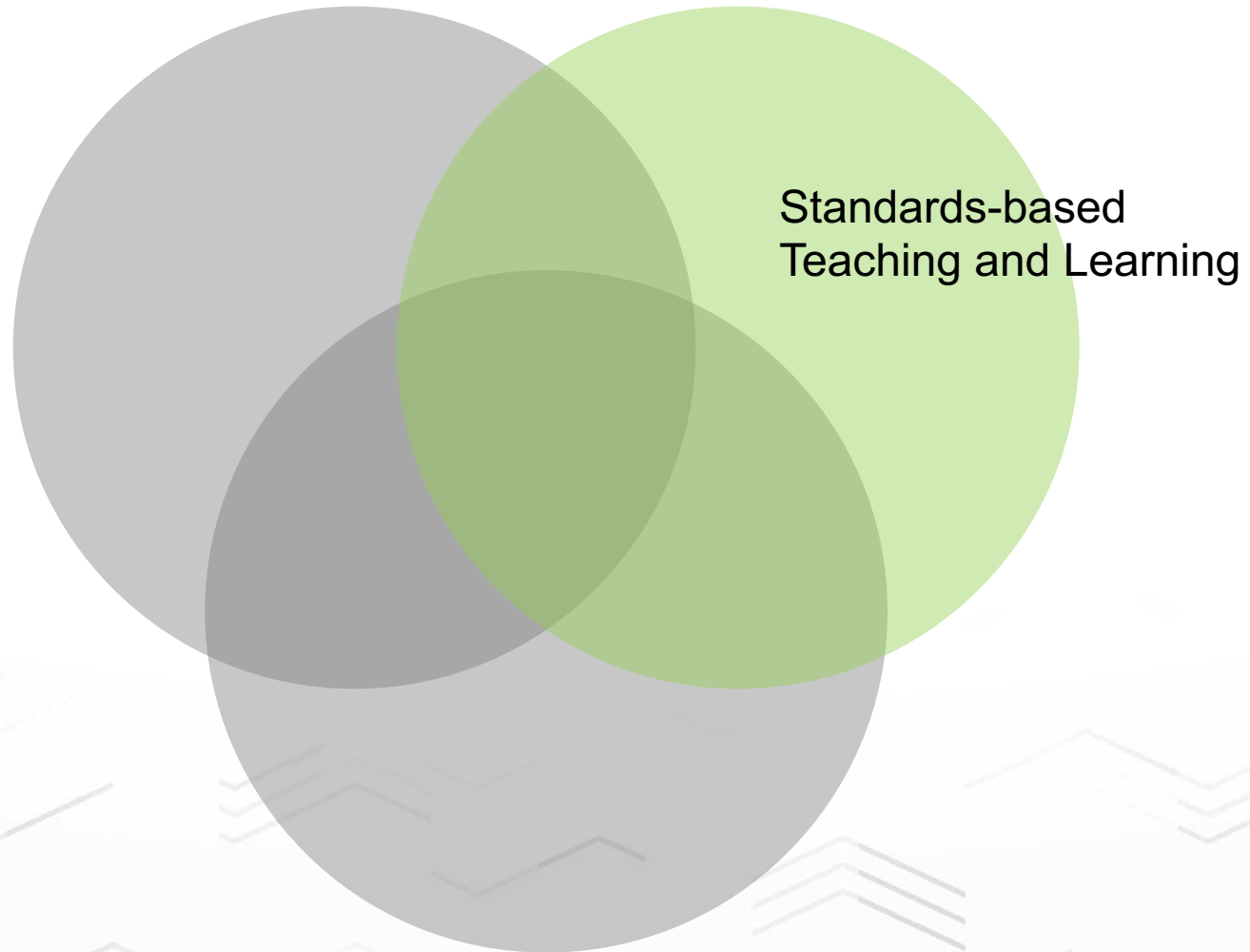

## What to Expect from Ed Directions

- Support the ongoing rollout of the new standards
- Focus on building a foundation of best practices (teaching/learning)
- Facilitate the review and revision of the SIP
- Support student-focused PLC processes
- Provide ad hoc professional development





THE SCHOOL IMPROVEMENT FRAMEWORK

# The State Change Initiative: Local Context

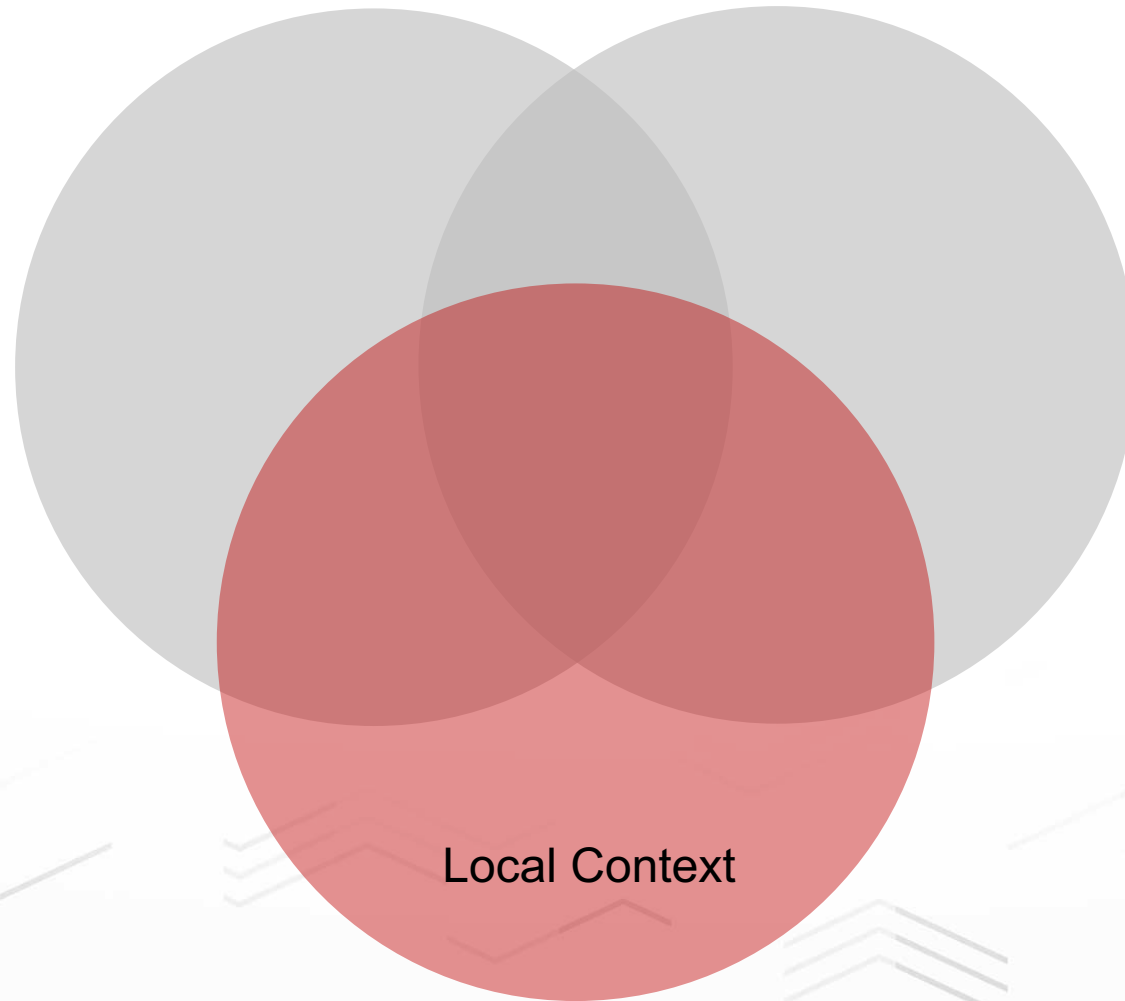



THE SCHOOL IMPROVEMENT FRAMEWORK

## What to Expect from Ed Directions

- Initial needs assessment
- Leads observe, interview, analyze data, and provide an initial analysis
- Facilitate the development of an initial school transformation plan
- Professional development and PLC Assistance

THE SCHOOL IMPROVEMENT FRAMEWORK

# School Improvement Framework

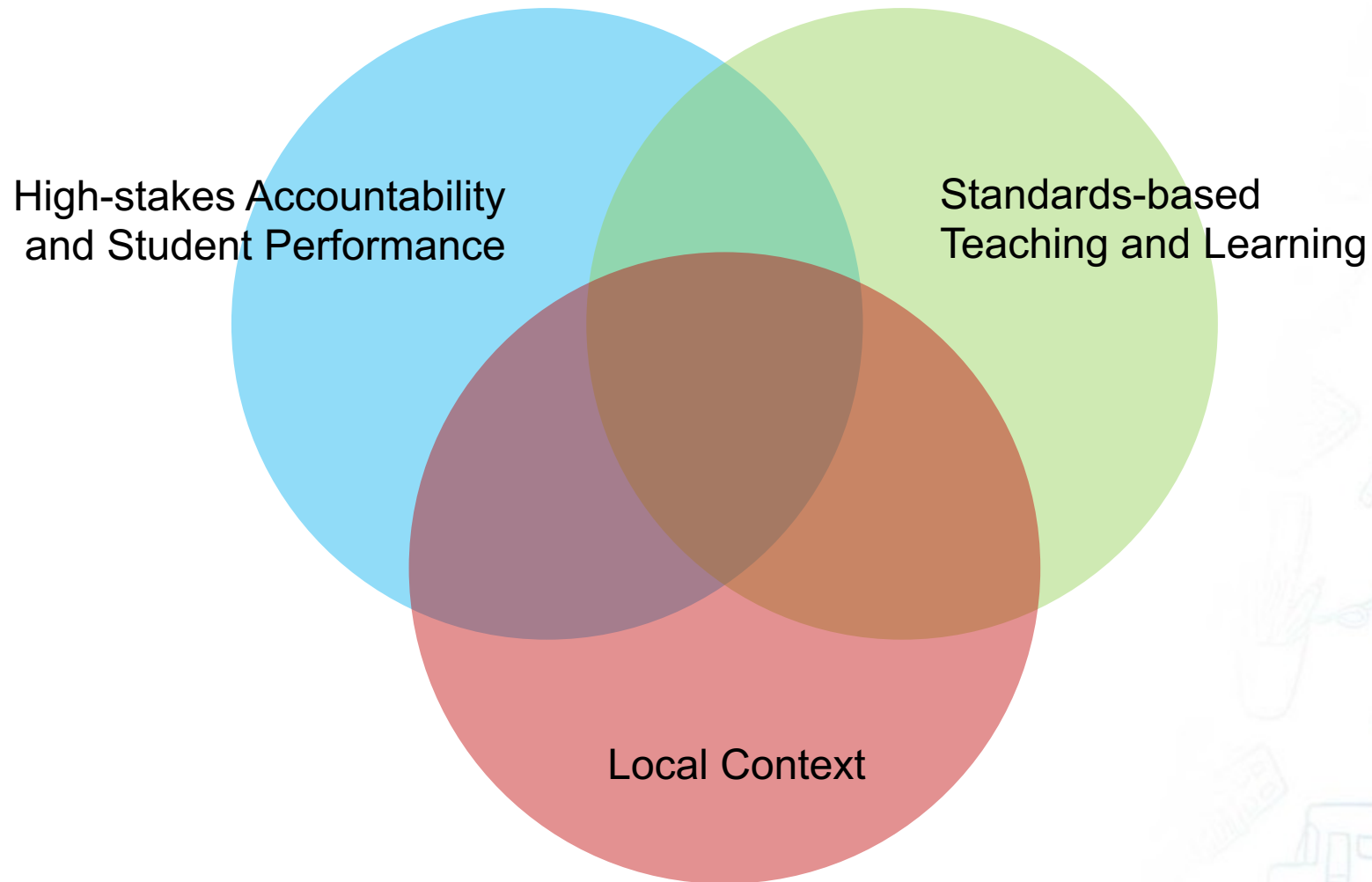



# *Section 2*

## Student as Learner vs. Student as Performer



THE 5 LEGGED MODEL OF STUDENT PERFORMANCE

# Core research –How Students Learn and Perform



THE 5 LEGGED MODEL OF STUDENT PERFORMANCE

# Core Research – How Students Learn

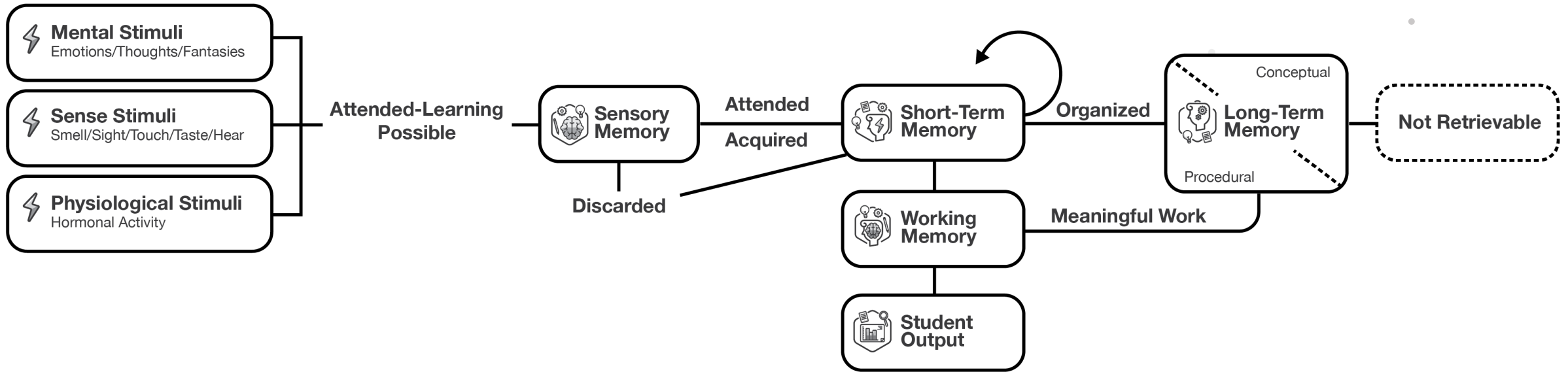



THE 5 LEGGED MODEL OF STUDENT PERFORMANCE

# 5 Legged Model of Student Performance

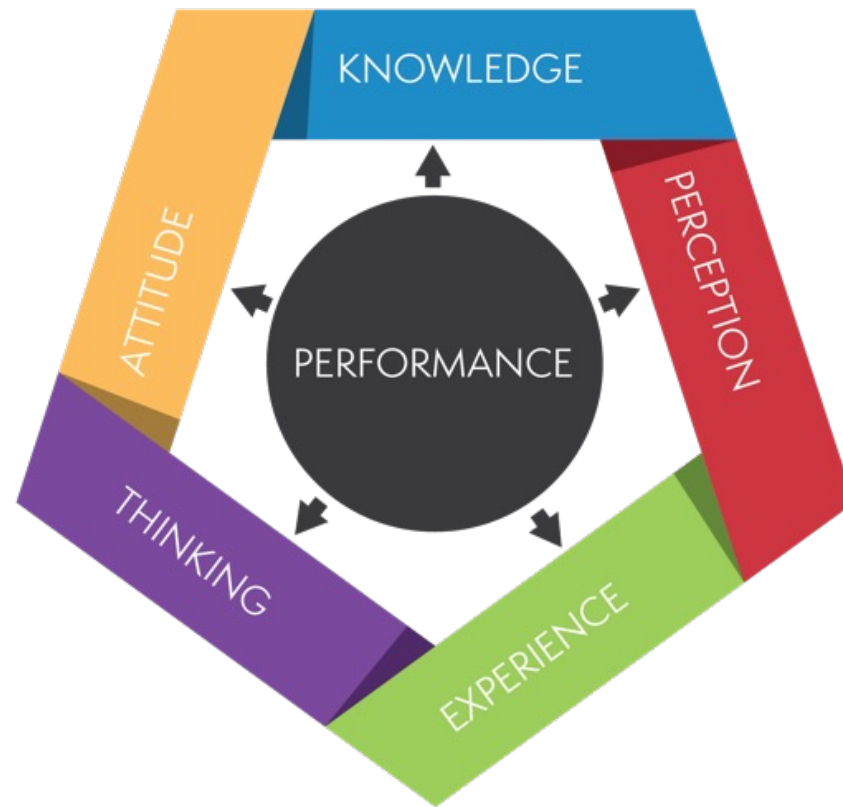

THE 5 LEGGED MODEL OF STUDENT PERFORMANCE

# 5 Legged Model of Student Performance

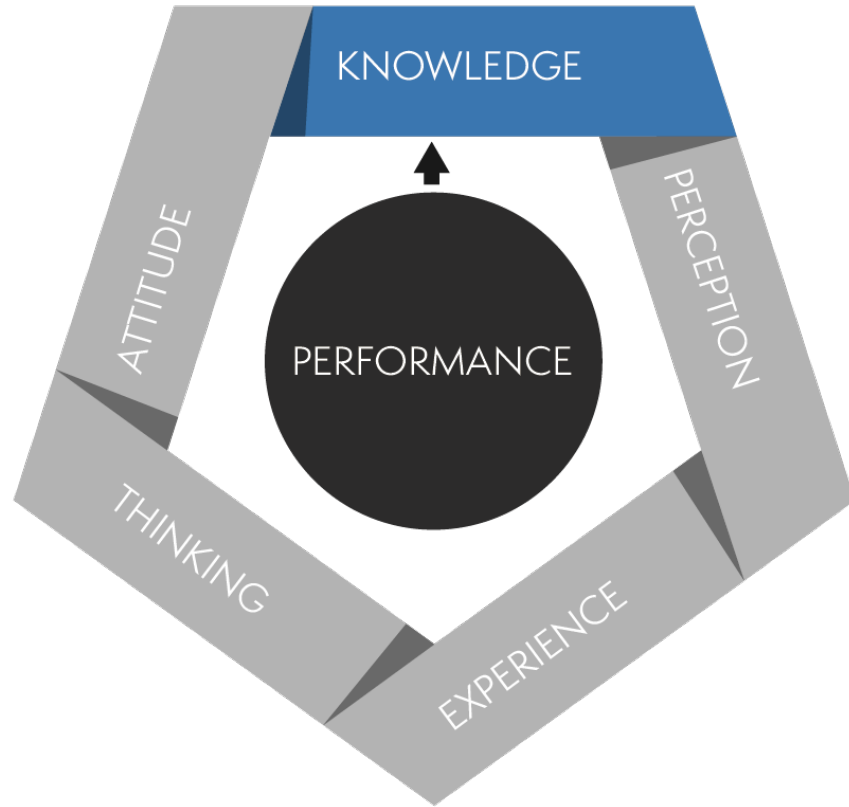







THE RHYTHM OF THE LEARNER YEAR

# The Rhythm of the Learner Year Timeline

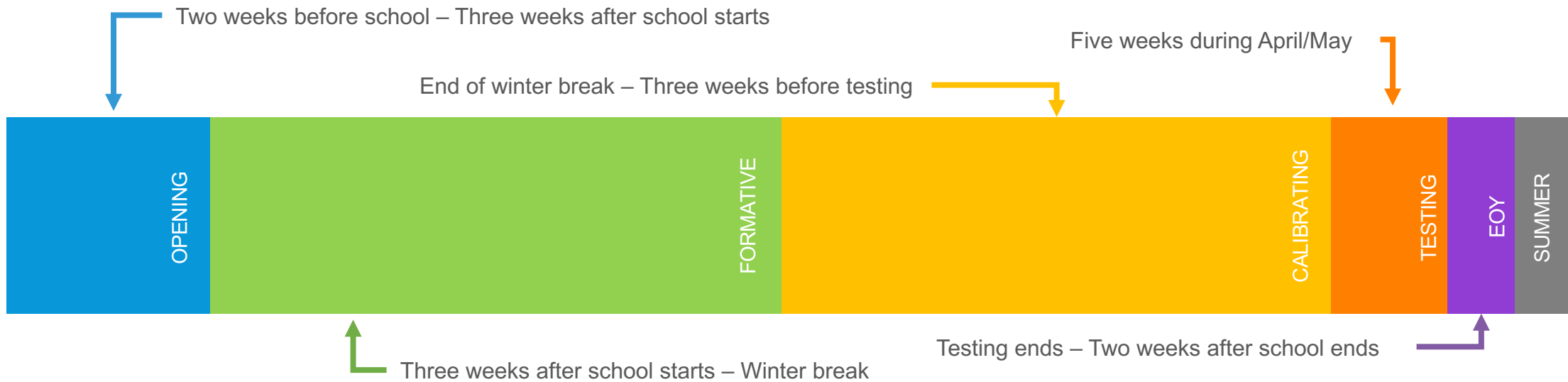

## What is the Rhythm of the Learner Year?

Ed Directions research base emphasizes the need to honor the learner in planning programs and curriculum

- The Opening Period
- The Formative Period
- The Calibrating Period
- The Testing Period
- End of Year (EOY) Period
- The Summer Period

## Opening of School Period

**Timeframe:** 2 weeks before school opens  
to 3 weeks after school opens

### The Priorities:

- Enculturing
- Preparing all students for success in class
- Mastering management and academic rituals and routines
- Building adult access to students
- Establishing work and performance expectations
- Jump starting critical reading, thinking and writing

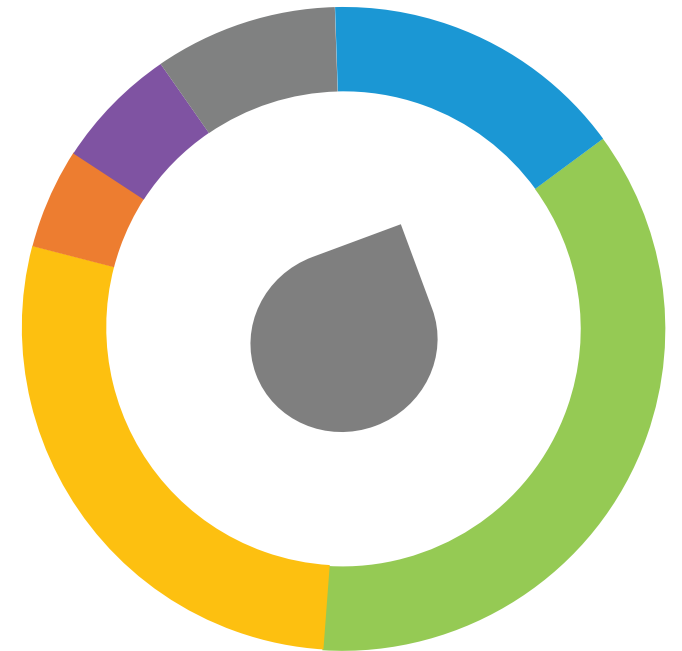



## The Formative Period

**Timeframe:** Week 3 to the beginning of winter break

### The Priorities:

- Building an independent learner
- Increasing potential as performer
- Building operational language
- Using critical reading, writing and thinking strategies
- Building basic reading and performing competencies
- Building a best effort comfort zone

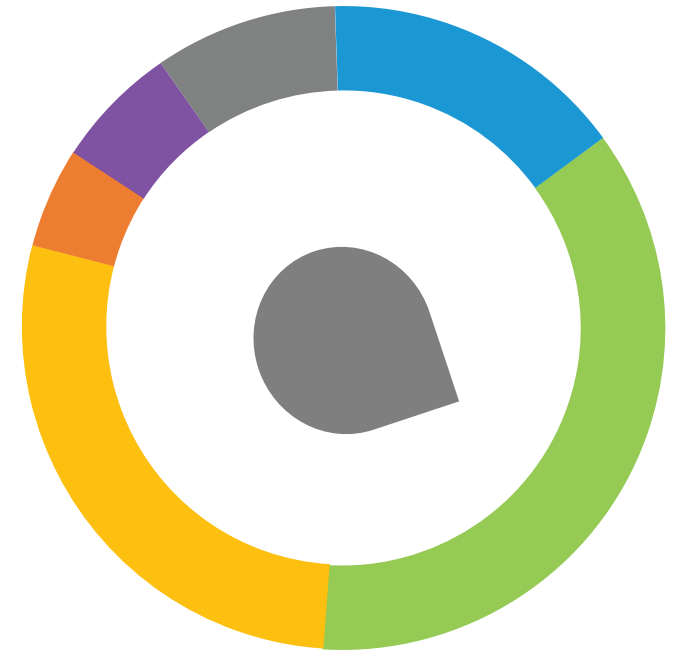

THE RHYTHM OF THE LEARNER YEAR

## Review and a Look Ahead

- What have we learned today
- How BAR process and how to use tool kit to unpack
- The next professional development session
- School Readiness Plan – (we will work on this in PD2)
- Next steps with Leadership Coaches
- Directions for working lunch
- Final questions or comments



# ED DIRECTIONS IN ACTION

FIND US ONLINE AT [HTTP://WWW.EDDIRECTIONS.COM](http://www.eddirections.com)

